

PREMIO CARPANELLI

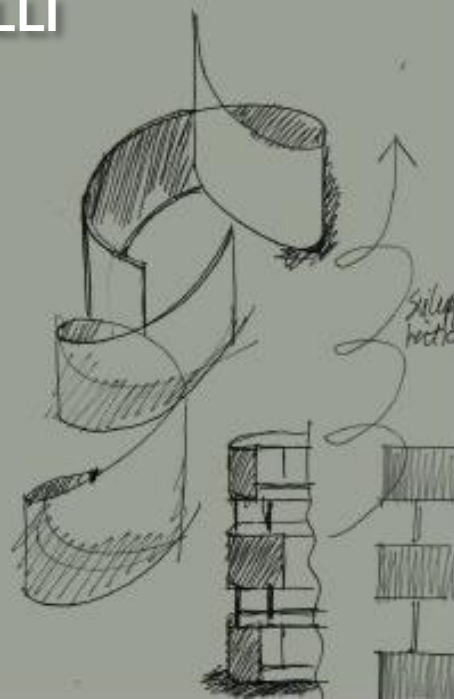
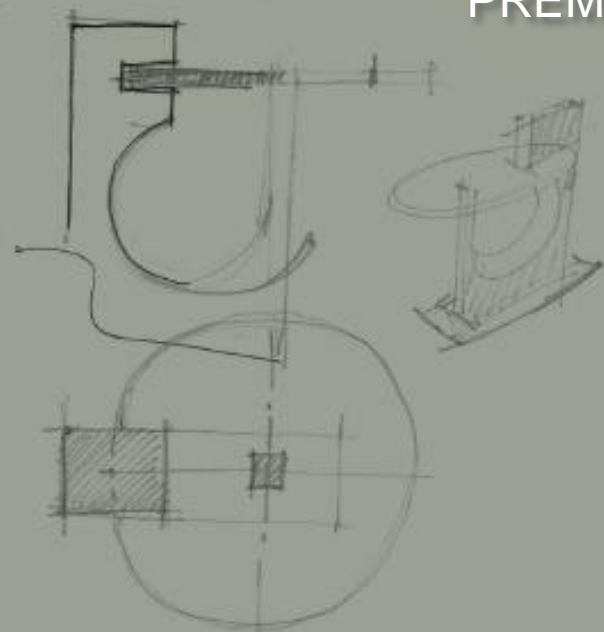

IDEAS4WOOD

Contest internazionale di design  
VI edizione

# L'AZIENDA

CARPANELLI srl, azienda di arredi con oltre 100 anni di storia dedicati all'alta ebanisteria ha oggi una clientela internazionale posizionata nel settore cd. Luxury, inteso come esperienza di autenticità, cura del dettaglio e espressione di artigianalità.

Elemento distintivo del Made in Italy apprezzato nel mondo inteso non come il semplice fatto che sia prodotto in Italia ma che sia espressione di **CREATIVITÀ** e **COMPETENZA** per un prodotto cd. "Bello e Ben Fatto".

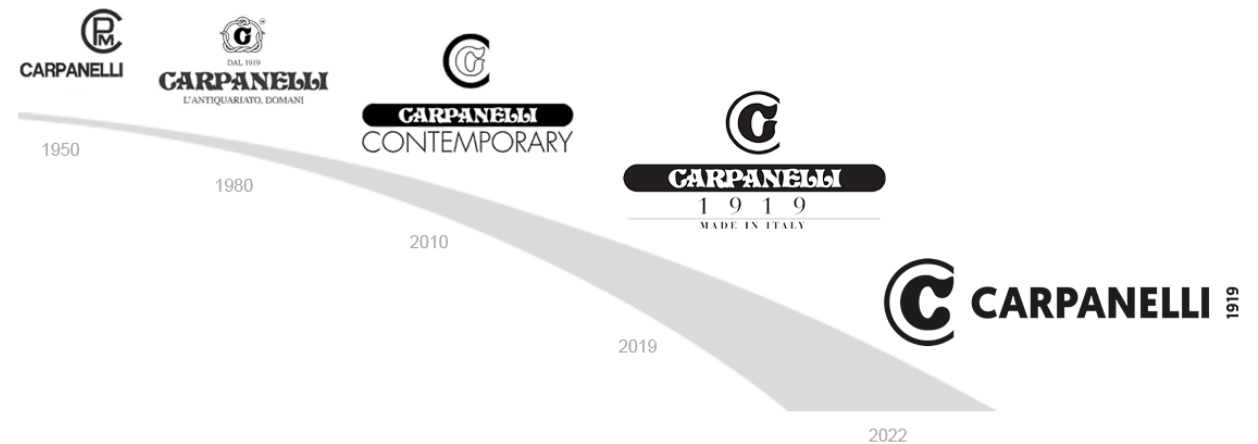

# CONTEST IDEAS4WOOD

Nell'ambito del 6° Design Contest IDEAS4WOOD 2023/2024 promuove il **Premio Carpanelli**.

Un viaggio progettuale ispirato allo stile e alla raffinatezza del proprio paese e tradotto in un oggetto d'arredo coordinato con il concept di Carpanelli «**A NEW TOUCH OF ELEGANCE**» e declinato secondo il linguaggio del design italiano.

Ogni idea progettuale deve essere pensata per le seguenti specifiche tipologie di prodotto:

- LIBRERIE
- MADIE e CONTENITORI
- COMPLEMENTI (es. CONSOLLE, DIVISORI, MOBILETTI)



# A NEW TOUCH OF ELEGANCE

È richiesto al partecipante:

Un percorso di ricerca sulle attuali tendenze del settore dell' arredamento.



A NEW TOUCH

L' elaborazione di un concetto attuale di eleganza intesa come utilizzo di materiali pregiati, eco-sostenibili, ricerca dei dettagli e artigianalità delle lavorazioni.



OF ELEGANCE

# A NEW TOUCH OF ELEGANCE

Ben considerate sono:

- il lavoro di ricerca delle **attuali tendenze** e l'**interpretazione originale** del tema del Contest;
- la valorizzazione del legno nelle sue **essenze** più **pregiate** quale materiale protagonista (*collezione Tabu 555 colors of wood*);
- ricerca di **abbinamenti** con nuovi materiali anche eco-compatibili che esprimano un concetto attuale di preziosità;
- l'attenzione al rispetto per il patrimonio forestale tramite l'impiego di un piallaccio di legno certificato **FSC®**.





## Strategia e valore della proposta

Carpanelli è un marchio evergreen, preziosamente elegante, oggi arricchito da un tocco di novità. Con i nuovi prodotti abbiamo cercato di intercettare le nuove tendenze mantenendo il DNA Carpanelli, sintesi di raffinata eleganza e forte impatto emotivo.

### **Valori e punti di forza**

Grande attenzione al cliente, standard qualitativi elevati e capacità di customizzazione. La novità si presenta nell'utilizzo di un materiale tradizionale e eco-sostenibile come il legno naturale, in maniera innovativa. Il mobile Carpanelli nasce da un percorso di ricerca e sperimentazione continua che rende possibile la realizzazione di prodotti di «alta artigianalità», creati attraverso l'accurata selezione di materiali pregiati tra cui legni, marmi, pelli e metalli di tendenza.

# Strategia e valore della proposta

## **In grado di offrire**

Carpanelli vuole essere oggi interprete di un'idea di lusso attuale, un'idea espressa attraverso la possibilità di personalizzare i nostri prodotti. Un vero servizio sartoriale su misura dedicato ai nostri clienti più esigenti, eleganti e al passo con i tempi.

## **Come riconoscere un mobile Carpanelli?**

Le ultime proposte esprimono una versione moderna di alta ebanisteria, presentata con un design elegante caratterizzato da linee leggere e dalla massima cura dei dettagli.



# IL BRAND PRISM TO-BE DI CARPANELLI

Fattori Interni

## FISICO

### Cosa offre la marca

- Linee morbide/sobrie
- Legni pregiati
- Intarsi moderni
- Materiali di qualità / preziosi (pelle, marmo, metallo)
- Colori sobri e tenui, senza ostentazione
- Effetti cromatici del legno
- Matericità sensoriale dei materiali
- Design moderno
- Equilibrio tra forme e rivestimenti

SENDER

- Elegante
- Ricerca ma non sopra le righe
- Ricerca stilistica coerente e mantenuta nel tempo (attenzione alle tendenze)
- Eleganza sobria

## PERSONALITÀ

Gli elementi fondamentali per distinguersi

## RELAZIONI

### Il valore aggiunto della marca

- Customizzazione
- Sartorialità
- Intimità nella relazione con il cliente
- Arredo senza tempo (duraturo)
- Cura del cliente
- Capace di leggere l'evoluzione del cliente moderno



- Made in Italy
- Qualità (bello e ben fatto)
- Eleganza
- Artigianalità
- 100 anni di attività
- Contemporaneità
- Innovazione e modernità (al passo con i tempi)

## CULTURA

I valori del brand

## RIFLESSO

### La clientela target

- Chi si vuole distinguere senza essere pacchiano
- Chi apprezza il lusso e il bello
- Possessori di auto di lusso
- Raffinato
- Alta capacità di spesa
- Attenzione agli influencer (negozi - architetti)

RECEIVER

- Casa come biglietto da visita
- Arredo che si tramanda (perché bello, non perché diverso) da preservare con cura e restaurare
- Intenditore di arredamento di qualità

## SELF-IMAGE

La percezione interiore della clientela

Fattori Esterni





















# GAE

*libreria*





ISPIRAZIONE  
E SVILUPPO ...

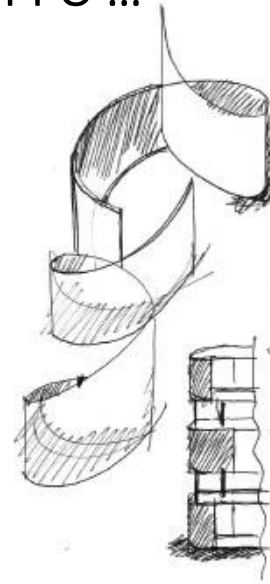

GAESYSTEM  
Bookcase



MATERICITÀ

LINEE MORBIDE



TAY SCURO

CUOIO CON  
CUCITURA

NOCE CANALETTO

TAY CHIARO

# GAE

*libreria*



# GAE

*family*



**GAE**  
*libreria*



**GAE**  
*media*



**GAE**  
*tavolini*

# ALFEA

*credenza*



## ISPIRAZIONE E SVILUPPO...

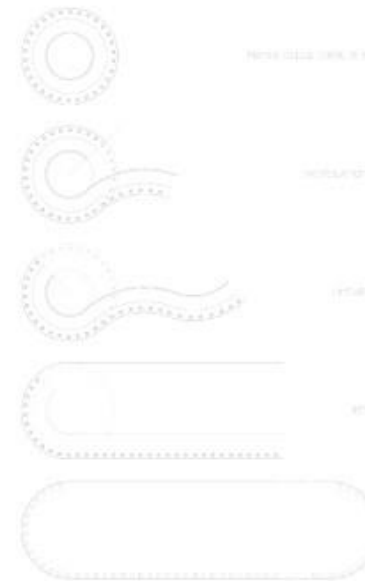
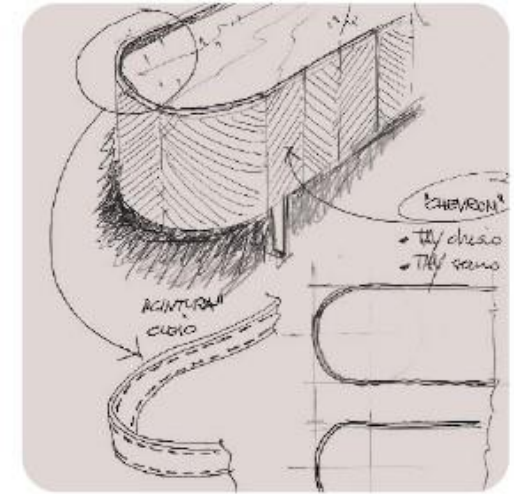

ALFEA  
Cupboard



MATERIALI PREGIATI

ARTIGIANALITÀ

Top in marmo  
**Calacatta oro**

Profilo in **cuoio**  
con cucitura

# ALFEA

*credenza*



LINEE MORBIDE

ELEGANZA

# ALFEA

*credenza*



Piedini in *metallo*  
finitura *bronzo-oro*





# ALFEA

*family*



**ALFEA**  
*credenza*



**ALFEA**  
*credenza alta*



# DOLFIN

*poltroncina*



## ISPIRAZIONE E SVILUPPO ...

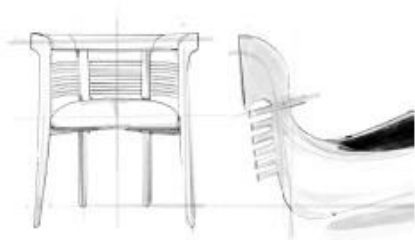

DOLFIN  
Small armchair

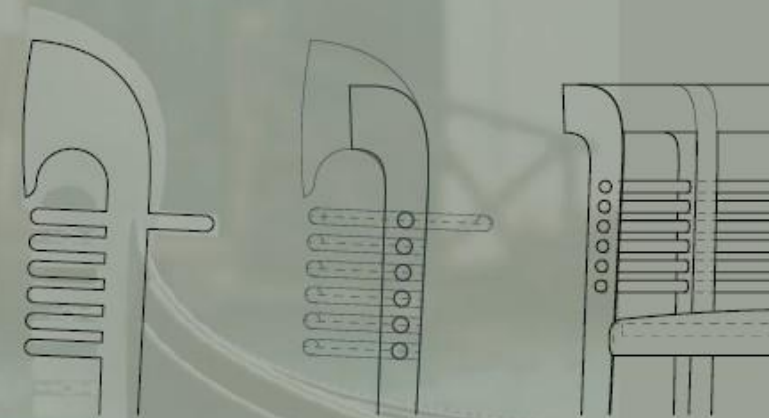
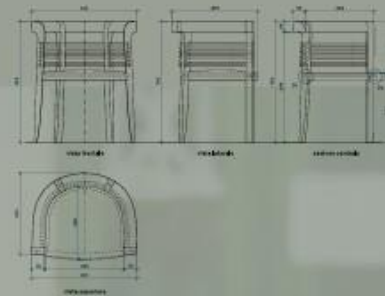

# DOLFIN

## SMALL ARMCHAIR



Finitura *noce Canaletto*



Finitura *nero ardesia*



Struttura in  
massello di frassino

# SEE YE

*tavolino*



IMPATTO EMOTIVO

DESIGN MODERNO

# SEE YE

*tavolino*

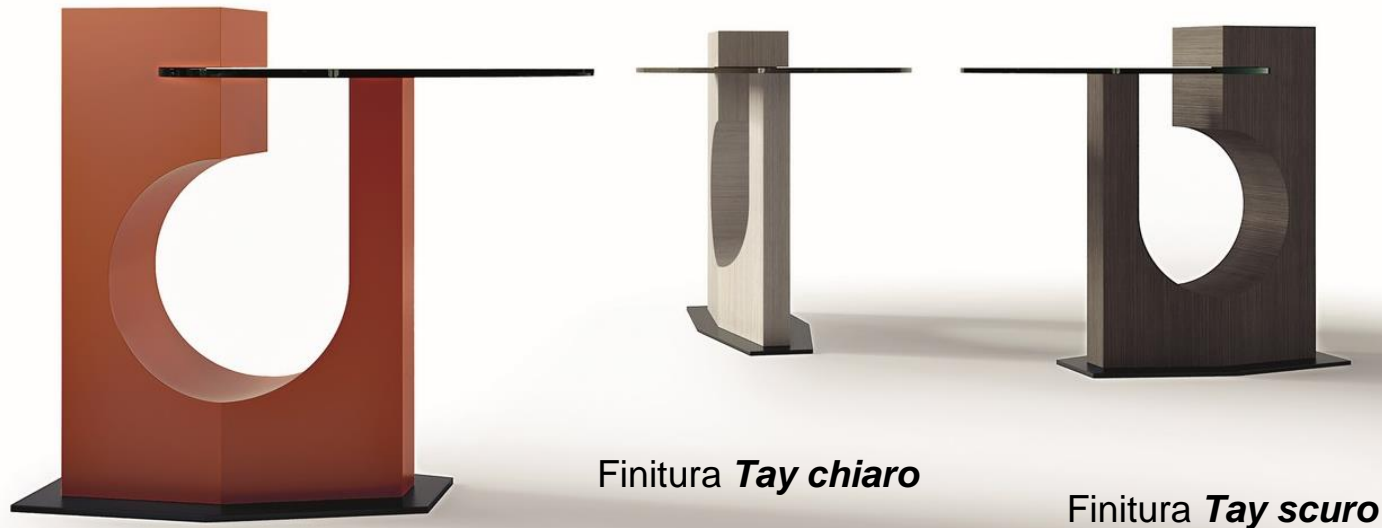

Finitura **laccata**

Finitura **Tay chiaro**

Finitura **Tay scuro**

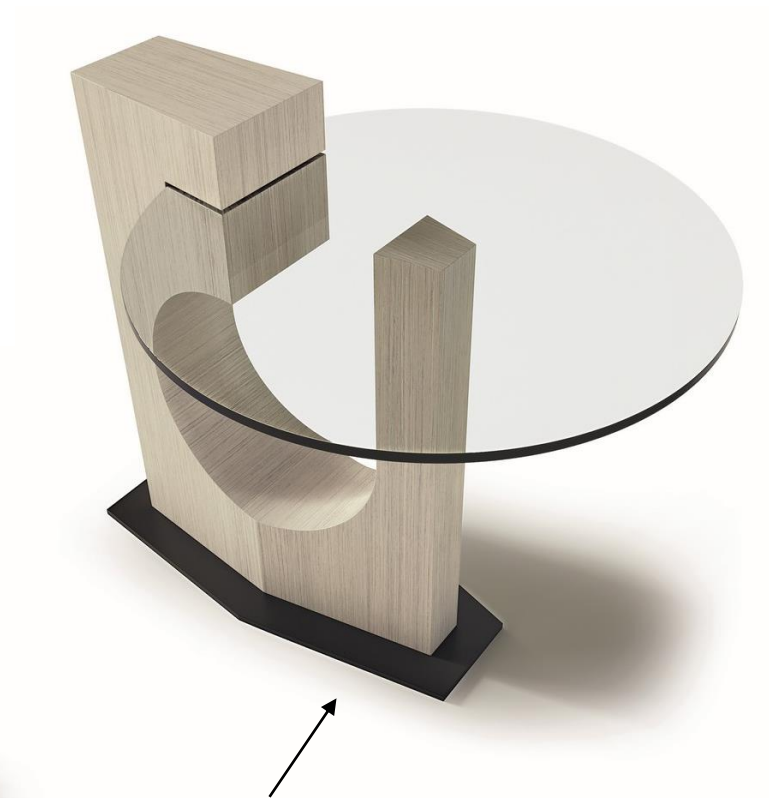

Base in **metallo**  
finitura **bronzo-oro**

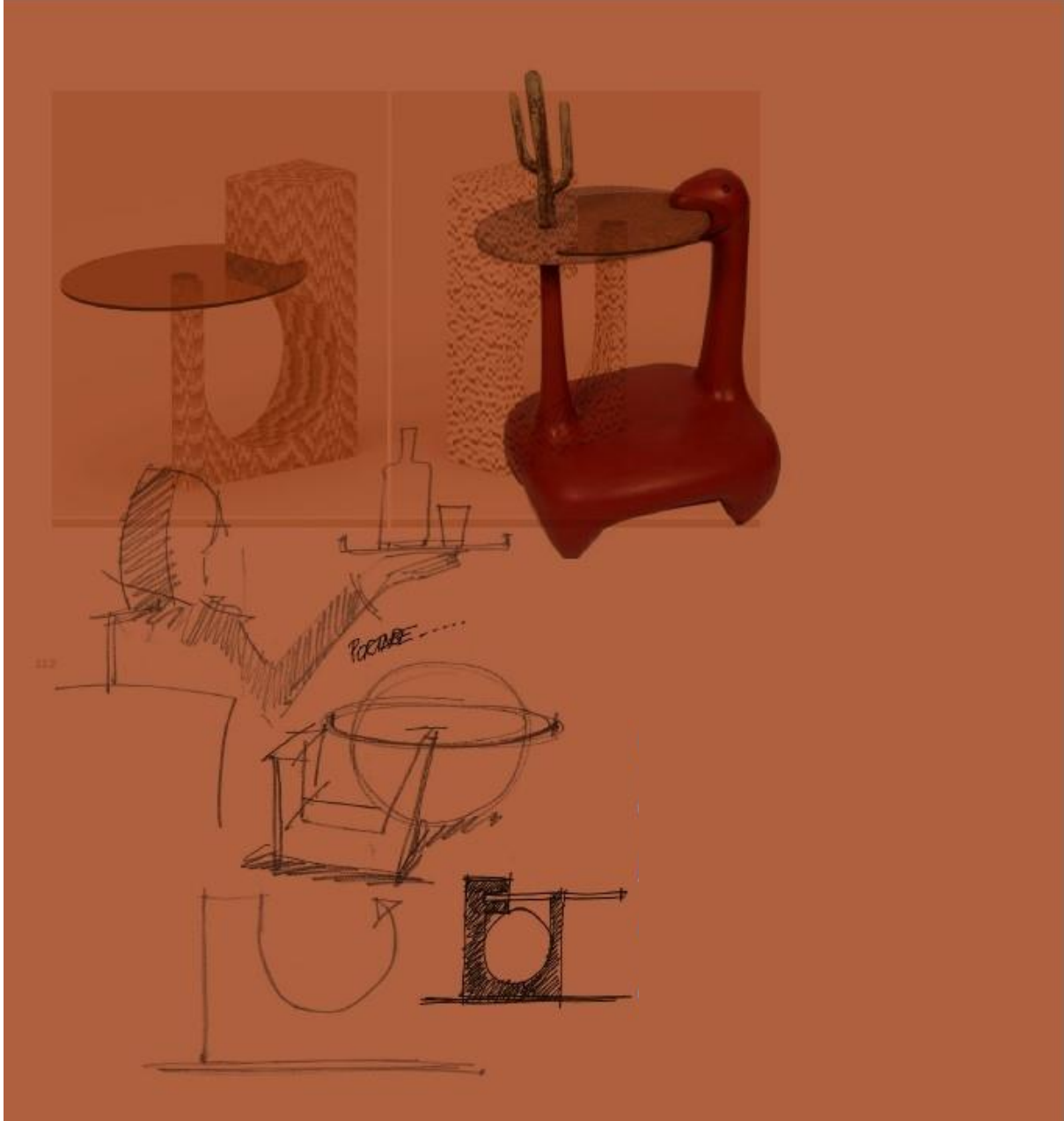

ISPIRAZIONE  
E SVILUPPO ...

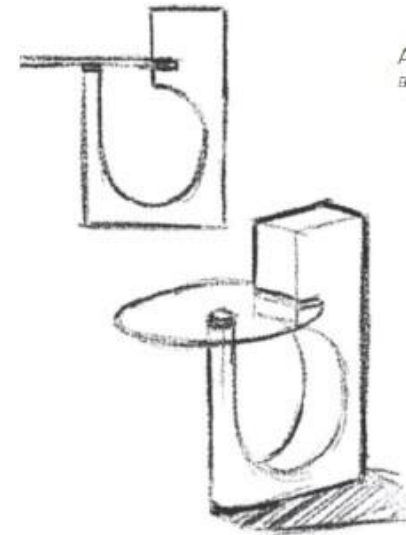

ALFEA  
Bookcase



# AIDA

*poltroncina*





DESIGN MODERNO

SOBRIA ELEGANZA

# AIDA

*poltroncina*



# DAFNE

*credenza*



# DAFNE

*credenza*

MATERIALI PREGIATI

DESIGN MODERNO

ELEGANZA E IMPATTO EMOTIVO

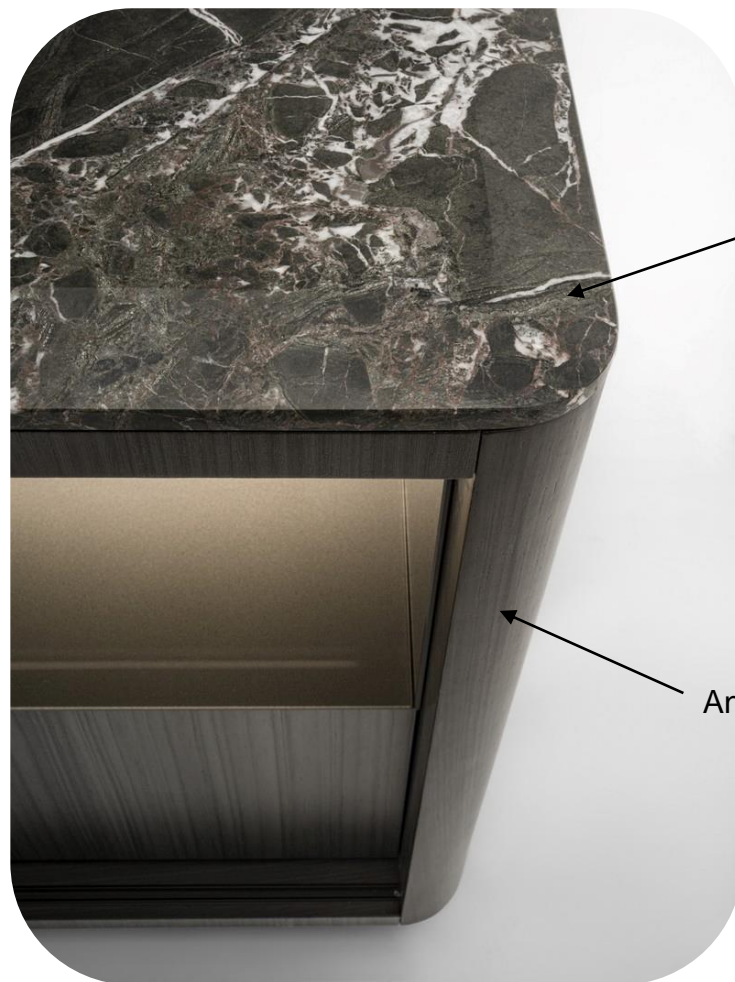

Top in marmo bisellato  
su tutto il perimetro

Angoli stondati



Box in vetro verniciato

Top in marmo Lepanto verde opaco

Tay scuro

Anta scorrevole su tutta la lunghezza



# DAFNE

*vetrina*

DETTAGLI PREZIOSI

DESIGN MODERNO

# DAFNE

*vetrina*



Fondale a specchio



Interni rivestiti in pelle





# A NEW TOUCH OF ELEGANCE

*Scarica i cataloghi dell'ultima collezione*

<https://we.tl/t-2Nmpf41prU>



A NEW TOUCH OF ELEGANCE 01



PREVIEW A NEW TOUCH OF ELEGANCE 02



[i4w@carpanelli.com](mailto:i4w@carpanelli.com)

